

Eight Hints for Better Scope Probing

Application Note 1603



8 Hints for Better Scope Probing

Probing is critical to making quality oscilloscope measurements, and often the probe is the first link in the oscilloscope measurement chain. If probe performance is not adequate for your application, you will see distorted or misleading signals on your oscilloscope. Selecting the right probe for your application is the first step toward making reliable measurements. How you use the probe also affects your ability to make accurate measurements and obtain useful measurement results. In this application note, you will find eight useful hints for selecting the right probe for your application and for making your scope probing better. The following probing tips will help you avoid most common probing pitfalls.

Hint #1 – Passive or active probe?

Hint #2 -- Probe loading check with two probes

Hint #3 -- Compensate probe before use

Hint #4 -- Low current measurement tips

Hint #5 -- Make safe floating measurements with a differential probe

Hint #6 -- Check the common mode rejection

Hint #7 -- Check the probe coupling

Hint #8 -- Damp the resonance

Hint

Passive or active probe?

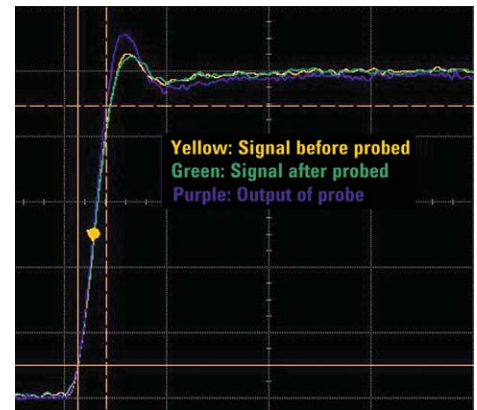
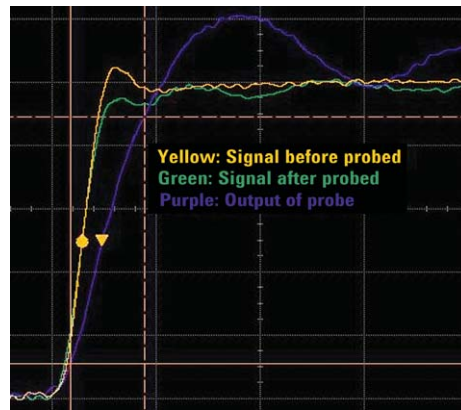

Figure 1-1. Comparison of passive and active probe measuring a signal that has a 600 psec rise time.

Agilent N2873A 500-MHz passive probe with 15-cm alligator ground lead

- Signal loaded, now has 740 psec edge
- Probe output contains resonance and measures 1.4 nsec edge

Agilent N2796A 2-GHz active probe with 1.8-cm ground lead

- Signal unaffected by probe, still has 630 psec edge
- Probe output matches signal and measure 555 psec

For general-purpose mid-to-low-frequency (less than 600-MHz) measurements, passive high-impedance resistor divider probes are good choices. These rugged and inexpensive tools offer wide dynamic range (greater than 300 V) and high input resistance to match a scope's input impedance. However, they impose heavier capacitive loading and offer lower bandwidths than low-impedance (z_0) passive probes or active probes. All in all, high-impedance passive probes are a great choice for general-purpose debugging and troubleshooting on most analog or digital circuits.

For high-frequency applications (greater than 600 MHz) that demand precision across a broad frequency range, active probes are the way to go. They cost more than passive probe and their input voltage is limited, but because of their significantly lower capacitive loading, they give you more accurate insight into fast signals.

In Figure 1-1 we see screen shots from a 600 MHz scope (the Agilent DSO 9064A) measuring a signal that has a 500 psec rise time. On the left, an Agilent N2873A 500 MHz passive probe was used to measure this signal. On the right, an Agilent N2796A 2 GHz single-ended active probe was used to measure the same signal. The yellow trace shows the signal before it was probed and is the same in both cases. The green trace shows the signal after it was probed, which is the same as the input to the probe. The purple trace shows the measured signal, or the output of the probe.

A passive probe loads the signal down with its input resistance, inductance and capacitance (green trace). You probably expect that your oscilloscope probe will not affect your signals in your device under test (DUT). However, in this case the passive probe does have an effect on the DUT. The probed signal's rise time becomes 4 ns instead of the expected 600 psec, partly due to the probe's input impedance, but also due to its limited 500-MHz bandwidth in measuring a 583-MHz signal ($0.35/600 \text{ psec} = 583 \text{ MHz}$).

The inductive and capacitive effects of the passive probe also cause overshoot and ripping effects in the probe output (purple trace). Some designers are not concerned about this amount of measurement error. For others, this amount of measurement error is unacceptable.

We can see that the signal is virtually unaffected when we attach an active probe such as Agilent's N2796A 2 GHz active probe to the DUT. The signal's characteristics after being probed (green trace) are nearly identical to its un-probed characteristics (N2796A 2 GHz trace). In addition, the rise time of the signal is unaffected by the probe being maintained at 555 psec. Also, the active probe's output (green trace) matches the probed signal (purple trace) and measures the expected 600 psec rise time. Using the 1156A active probe's 2 GHz bandwidth with superior signal fidelity and low probe loading makes this possible.

Key differences between passive and active probes are summarized below in figure 1-2.

	High Impedance Passive Probe	Active Probe
Power requirement	NO	YES
Loading	Heavy capacitive loading and low Resistive loading	Best overall combination of resistive and capacitive loading
Bandwidth	up to 600 MHz	up to 30 GHz
Applications	General purpose mid-to-low frequency measurements	High-frequency applications
Ruggedness	Very rugged	Less rugged
Max input voltage	~ 300V	~ 40V
Typical Prices	\$100-\$500	>\$1k

Figure 1-2. Comparison of high-impedance passive and active probes

Hint

Probe loading check with two probes

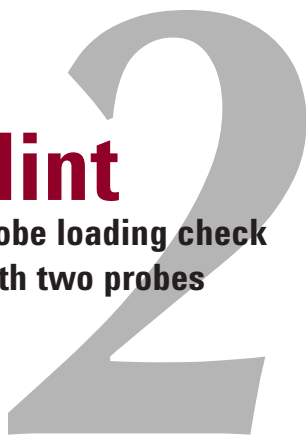

Before probing a circuit, connect your probe tip to a point on your circuit and then connect your second probe to the same point. Ideally, you should see no change on your signal. If you see a change, it is caused by the probe loading.

In an ideal world, a scope probe would be a non-intrusive (having infinite input resistance, zero capacitance and inductance) wire attached to the circuit of interest and it would provide an exact replica of the signal being measured. But in the real world, the probe becomes part of the measurement and it introduces loading to the circuit.

To check the probe loading effect, first, connect one probe to the circuit under test or a known step signal and the other end to the scope's input. Watch the trace on the scope screen, save the trace and recall it on the screen so that the trace remains on the screen for a comparison. Then, using another probe of the same kind, connect to the same point and see how the original trace changes over the double probing.

You may need to make adjustments to your probing or consider using a probe with lower loading to make a better measurement. For instance, in this example, shortening the ground lead did the trick. In Figure 2-2, the circuit ground is probed with a long 18 cm (7") ground lead.

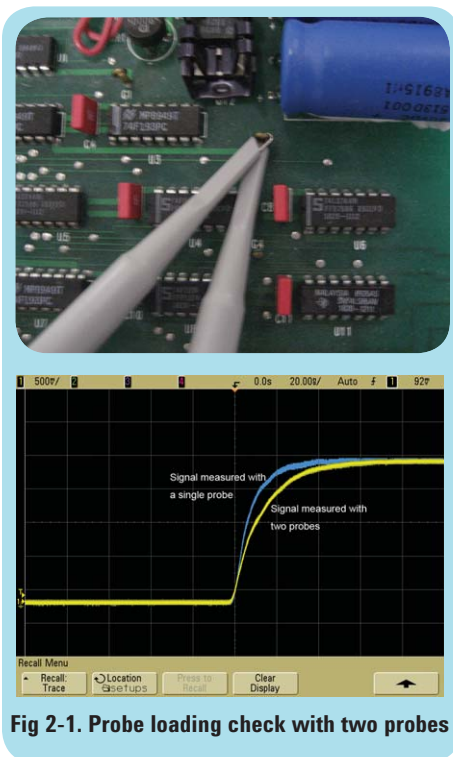

Fig 2-1. Probe loading check with two probes

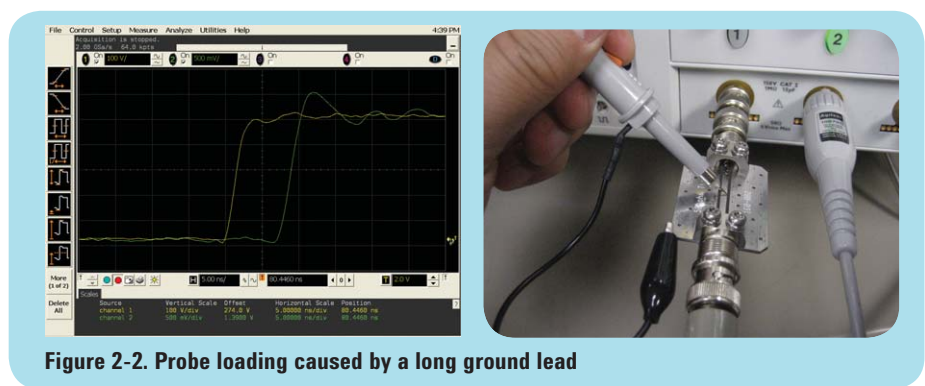

Figure 2-2. Probe loading caused by a long ground lead

In Figure 2-3, the same signal ground is probed with a short spring-loaded ground lead. The ringing on the probed signal (purple trace) went away with the shorter ground lead.

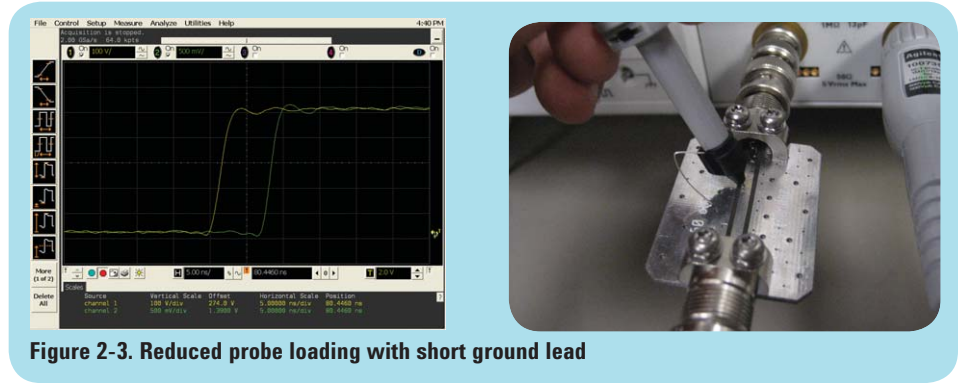

Figure 2-3. Reduced probe loading with short ground lead

Hint 3

Compensate probe before use

Most probes are designed to match the inputs of specific oscilloscope models. However, there are slight variations from scope to scope and even between different input channels in the same scope. Make sure you check the probe compensation when you first connect a probe to an oscilloscope input because it may have been adjusted previously to match a different input. To deal with this, most passive probes have built-in compensation RC divider networks. Probe compensation is the process of adjusting the RC divider so the probe maintains its attenuation ratio over the probe's rated bandwidth.

If your scope can automatically compensate for the performance of probes, it makes sense to use that feature. Otherwise, use manual compensation to adjust the probe's variable capacitance. Most

scopes have a square wave reference signal available on the front panel to use for compensating the probe. You can attach the probe tip to the probe compensation terminal and connect the probe to an input of the scope. Viewing the square wave reference signal, make the proper adjustments on the probe using a small screw driver so that the square waves on the scope screen look square.



Figure 3-1. Use a small screw driver to adjust the probe's variable capacitance.

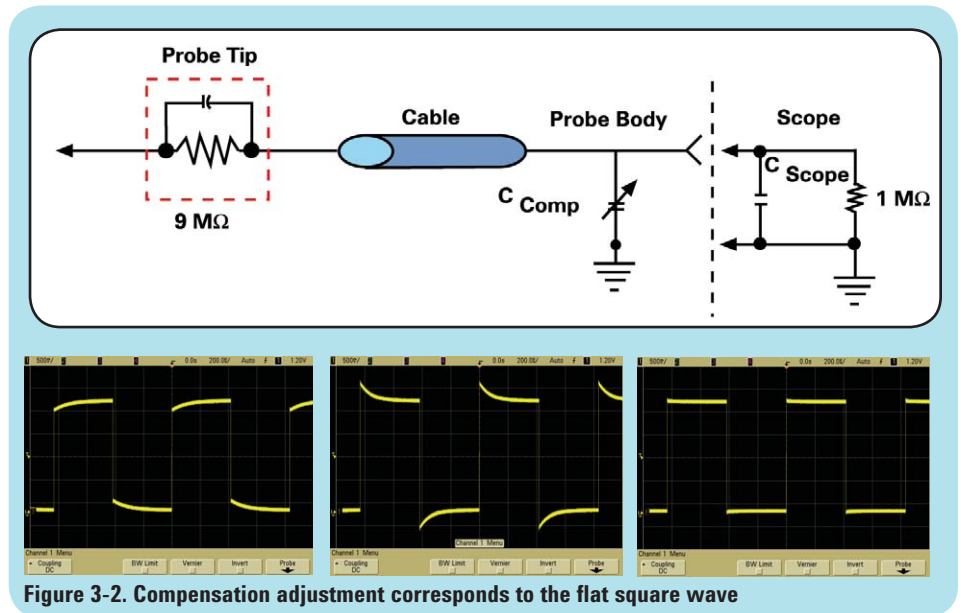

Figure 3-2. Compensation adjustment corresponds to the flat square wave

The diagram at the top of Figure 3-2 shows how to properly adjust the compensating capacitor in the termination box at the end of the probe. As you can see in the picture, you can have either overshoot or undershoot on the square wave when the

low-frequency adjustment is not properly made. This will result in high-frequency inaccuracies in your measurements. It's very important to make sure this compensation capacitor is correctly adjusted.

Hint

Low current measurement tips



In recent years, engineers working on mobile phones and other battery-powered devices have demanded higher-sensitivity current measurement to help them ensure the current consumption of their devices is within acceptable limits. Using a clamp-on current probe with an oscilloscope is an easy way to make current measurement that does not necessitate breaking the circuit. But this process gets tricky as the current levels fall into the low milliamperes range or below.

As the current level decreases, the oscilloscope's inherent noise becomes a real issue. All oscilloscopes exhibit one undesirable characteristic – vertical noise. When you are measuring low-level signals, measurement system noise may degrade your actual signal measurement accuracy. Since oscilloscopes are broadband measurement instruments, the higher the bandwidth of the oscilloscope, the higher the vertical noise will be. You need to carefully evaluate the oscilloscope's noise characteristics before you make measurements. The baseline noise floor of a typical 500-MHz bandwidth oscilloscope measured at its most sensitive V/div setting is approximately 2 mV peak-to-peak. In making low-level measurements, it is important to note that the acquisition memory on the oscilloscope can affect the noise floor.

On the other hand, a modern AC/DC current probe such as Agilent's N2783A or N2893A 100-MHz current probe is capable of measuring 5 mA of AC or DC current with approximately 3% accuracy. The current probe is designed to output 0.1 V per one ampere current input. In other words, the oscilloscope's inherent 2-mVpp noise can be a significant source of error if you are measuring less than 20 mA of current.

So, how do you minimize the oscilloscope's inherent noise? With modern digital oscilloscopes, there are a number of possible approaches:

1. Bandwidth limit filter – Most digital oscilloscopes offer bandwidth limit filters that can improve vertical resolution by filtering out unwanted noise from input waveforms and by decreasing the noise bandwidth. Bandwidth limit filters are implemented with either hardware or software. Most bandwidth limit filters can be enabled or disabled at your discretion.
- 2) High-resolution acquisition mode Most digital oscilloscopes offer 8 bits of vertical resolution in normal acquisition mode. High-resolution mode on some oscilloscope offers much higher vertical resolution, typically up to 12-16 bits, which reduces vertical noise and increases vertical resolution. Typically, high-resolution mode has a large effect at slow time/div settings, where the number of on-screen data points captured is large. Since high-resolution mode acquisition averages adjacent data points from one trigger, it reduces the sample rates and bandwidth of the oscilloscope.

- 3) Averaging mode – When the signal is periodic or DC, you can use averaging mode to reduce the oscilloscope's vertical noise. Averaging mode takes multiple acquisitions of a periodic waveform and creates a running average to reduce random noise. High-resolution mode does reduce the sample rates and bandwidth of the signal, whereas normal averaging does not. However, averaging mode compromises the waveform update rate as it takes multiple acquisitions to average out the waveforms and draws a trace on the screen. The noise reduction effect is larger than with any of the methods above as you select a greater number of averages.

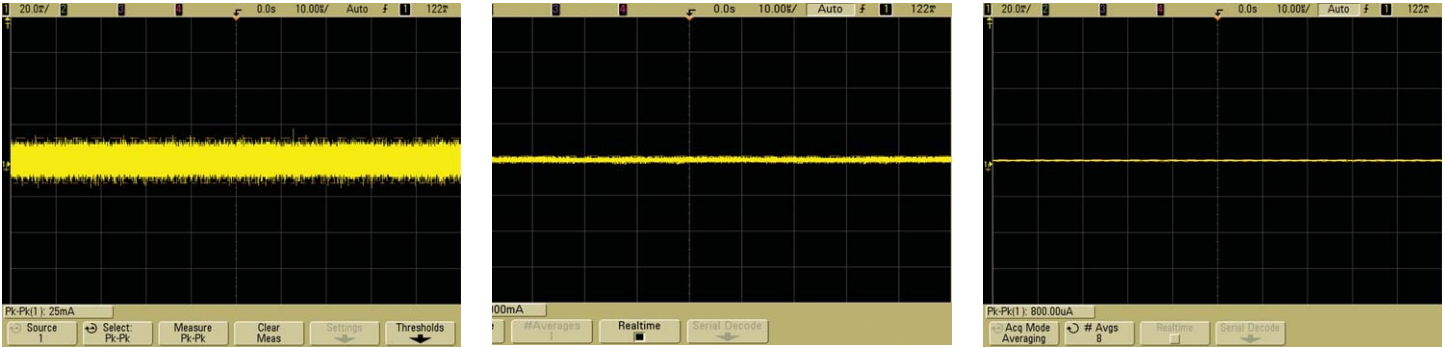

Figure 4-1. There are a number of possible approaches to reduce scope’s inherent vertical noise.

Now that you know how to lower the oscilloscope’s vertical noise with one of the techniques above, let’s take a look at how to improve accuracy and sensitivity of a current probe. There are a number of different types of current probes. The one that offers the most convenience and performance is a clamp-on AC/DC current probe that you can clip on a current-carrying conductor to measure AC and DC current. Agilent’s N2780A Series current probe is an example.

Two useful tips for using this type of current probe:

1. Remove magnetism (demagnetize/ degauss) and DC offset

To ensure accurate measurement of low-level current, you need to eliminate residual magnetism by demagnetizing the magnetic core. Just as you would



Figure 4-2. To improve current probe’s accuracy remove magnetism and DC offset

remove undesired magnetic field built up within a CRT display to improve picture quality, you can degauss or demagnetize a current probe to remove any residual magnetization. If a measurement is made while the probe core is magnetized, an offset voltage proportional to the residual magnetism can occur and induce measurement error. It is especially important to demagnetize the magnetic core whenever you connect the probe to power on/off switching or excessive input current. In addition, you can correct a probe’s undesired voltage offset or temperature drift using the zero adjustment control on the probe.

2. Improve the probe sensitivity
A current probe measures the magnetic field generated by the current flowing through the jaw of a probe head. Current probes generate voltage output proportional to the input current. If you are measuring DC or low-frequency AC signals of small amplitude, you can increase the measurement sensitivity on the probe by winding several turns of the conductor under test around the probe. The signal is multiplied by the number of turns around the probe. For example, if a conductor is wrapped around the probe 5 times and the oscilloscope shows a reading of 25 mA, the actual current flow is 25 mA divided by 5, or 5 mA. You can improve the sensitivity of the current probe by a factor of 5 in this case.

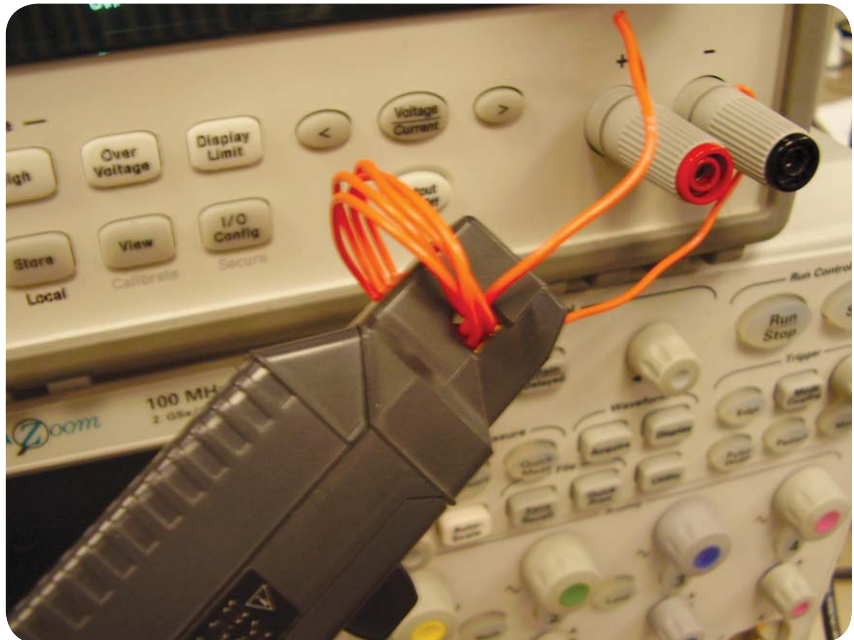

Figure 4-3. Improve the probe sensitivity by winding several turns of the conductor under test around the probe

Hint

Making safe floating measurements with a differential probe

Scope users often need to make floating measurements where neither point of the measurement is at earth ground potential. For example, suppose you measure a voltage drop across the input and output of a linear power supply's series regulator U1. Either the voltage in or out pin of the regulator is not referenced to ground.

A standard oscilloscope measurement where the probe is attached to a signal point and the probe tip ground lead is attached to circuit ground is actually a measurement of signal difference between the test point and earth ground. Most scopes have their signal ground terminals (or outer shells of the BNC interface) connected to the protective earth ground system. This is done so that all signals applied to the scope have a common connection point. Basically all scope measurements are with respect to "earth" ground. Connecting the ground connector to any of the floating points essentially pulls down the probed point to the earth ground, which often causes spikes or malfunctions on the circuit. How do you get around this floating measurement problem?

A popular yet undesirable solution to the need for a floating measurement is the "A-B" technique using two single-ended probes and a scope's math function. Most

digital oscilloscopes have a subtract mode where the two input channels can be electrically subtracted to give the difference in a differential signal. For decent results, each probe used should be matched and compensated before using it. In this method, the common mode rejection ratio is typically limited to less than -20dB (10:1). If the common mode signal on each probe is very large and differential signal is much smaller, any gain difference between the two sides will significantly alter their "differential" or "A-B" result. A good sanity check here would be to double probe the same signal and see what the "A-B" shows them.

Using a high-voltage differential probe such as Agilent's N2790A is a much better solution for making safe, accurate floating measurements with any oscilloscope. With a true differential amplifier in the probe head, the N2790A is rated to measure differential voltage up to 1,400 VDC + peak AC with CMRR of -70 dB at 10 MHz. Use a differential probe with sufficient dynamic range and bandwidth for your application to make safe and accurate floating measurements.

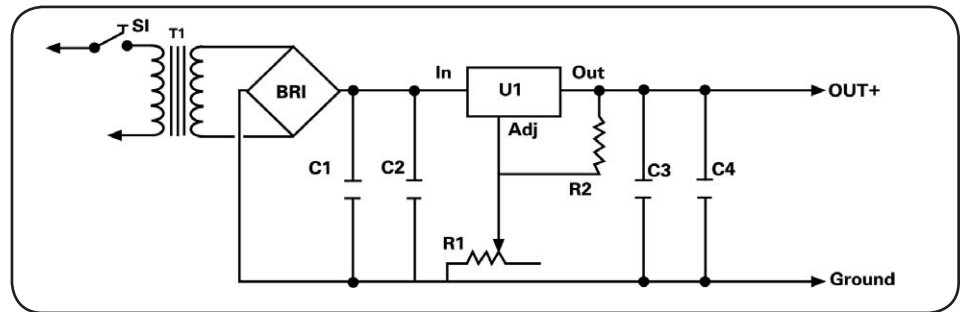

Figure 5-1. When measurement is not ground referenced, a differential measurement solution is necessary.

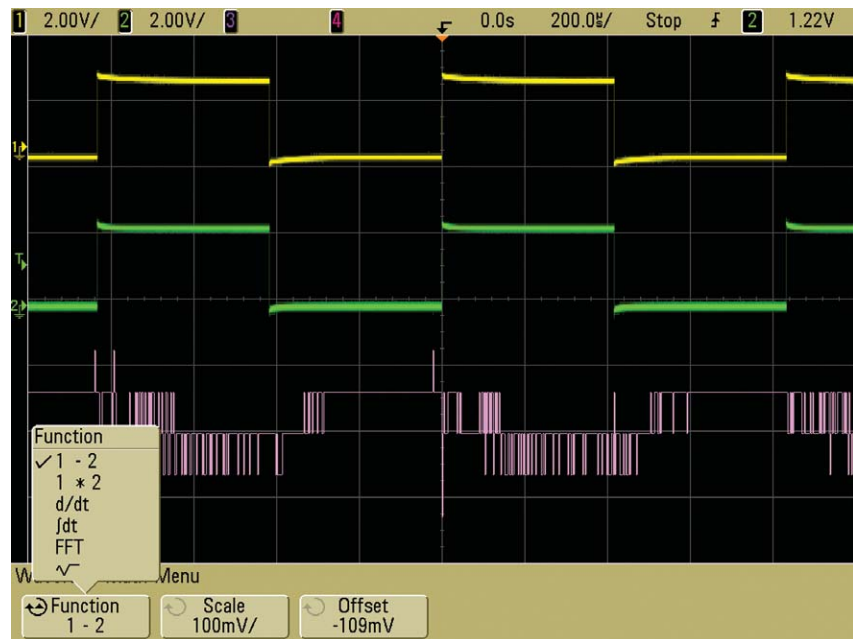

Figure 5-2. As a sanity check, double probe the same signal and see what the "A-B" looks like.

Hint

Check the common mode rejection

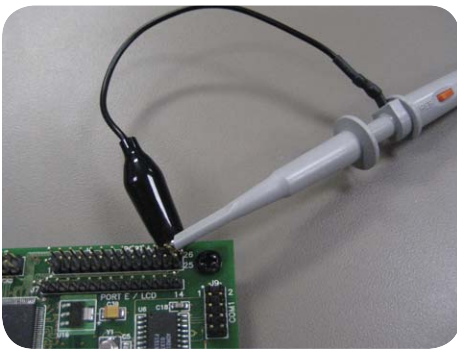

Figure 6-1. Connect both probe tips to the ground and see if any signals appear on the screen.

One of the most misunderstood issues with probing is that common mode rejection can limit the quality of a measurement. With either a single-ended or differential probe, it is always worthwhile to connect both probe tips to the ground of the DUT and see if any signals appear on the screen.

If signals appear, they show the level of signal corruption that is due to lack of common mode rejection. Common mode noise currents caused by sources other than the signal being measured can flow from ground in the DUT through the probe

ground and onto the probe cable shield. Sources of common mode noise can be internal to the DUT or external to it, such as power line noise, EMI or ESD currents.

A long ground lead on a single-ended probe can make this problem very significant. A single-ended probe does suffer from lack of common mode rejection. Differential active probes provide much higher common-mode rejection ratios, typically as high as 80 dB (10,000:1).

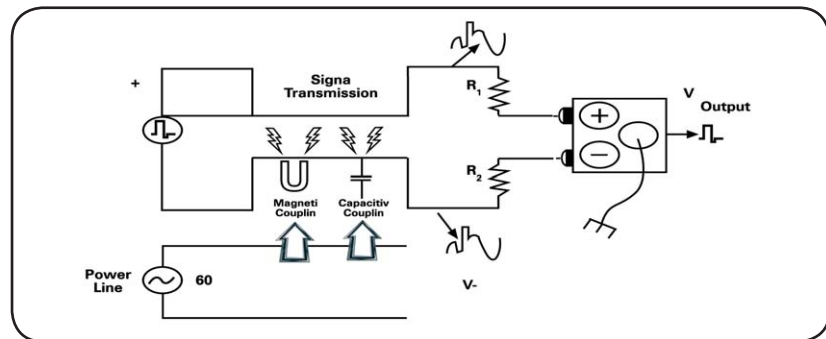

Figure 6-2. Differential active probe provides much higher common mode rejection ratio effectively eliminating common mode noise current.

Hint

Check the probe coupling

With your probe connected to a signal, move the probe cable around and grab it with your hands. If the waveform on the screen varies significantly, energy is being coupled onto the probe shield, causing this variation. Using a ferrite core on the probe cable may help improve probing accuracy by reducing the common mode noise currents on the cable shield. A ferrite

core on the probe cable generates a series impedance in parallel with a resistor in the conductor. The addition of the ferrite core to the probe cable rarely affects the signal because the signal passes through the core on the center conductor and returns through the core on the shield, resulting in no net signal current flowing through the core.

The position of the ferrite core on the cable is important. For convenience, you may be tempted to place the core at the scope end. This would make the probe head lighter and easier to handle. However, the core's effectiveness would be reduced substantially by locating the core at the probe interface end of the cable.

Reducing the length of the ground lead on a single-ended probe will help some. Switching to a differential probe will

typically help the most. Many users don't understand that the probe cable environment can cause variations in their measurements, especially at higher frequencies, and this can lead to frustration with the repeatability and quality of measurements.



Figure 7-1. Using a ferrite core on the probe cable may help improve probing accuracy

Hint

Damp the resonance

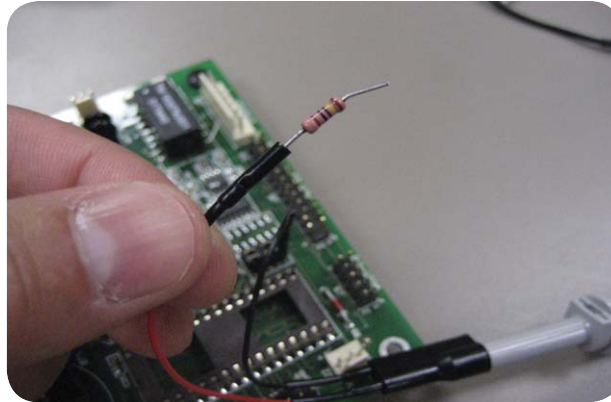

Figure 8-1. Put a resistor at the tip to damp the resonance of the added wire.

The performance of a probe is highly affected by the probe connection. As the speeds in your design increase, you may notice more overshoot, ringing, and other perturbations when connecting an oscilloscope probe. Probes form a resonant circuit where they connect to the device. If this resonance is within the bandwidth of the oscilloscope probe you are using, it will be difficult to determine if the measured perturbations are due to your circuit or the probe.

If you have to add wires to the tip of a probe to make a measurement in a tight environment, put a resistor at the tip to damp the resonance of the added wire.

For a single-ended probe, put the resistance only on the signal lead and try to keep the ground lead as short as possible. For a differential probe, put resistors at the tip

of both leads and keep the lead lengths the same. The value of the resistor can be determined by first probing a known step signal through a fixture board like the Agilent E2655B into a scope channel. Then probe the signal with your proposed wire with a resistor at the tip. When the resistance value is right, you should see a step shaped much like the test step, except it may be low-pass filtered. If you see excessive ringing, increase the resistor value.

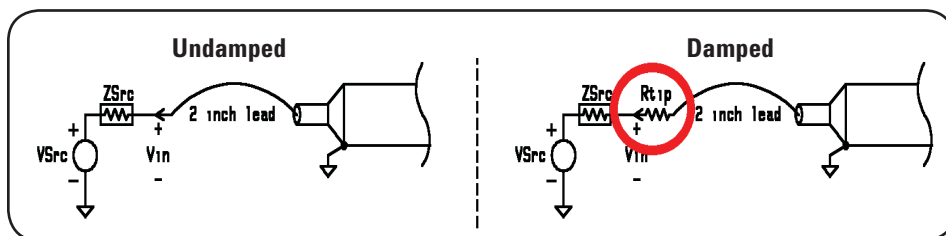

Figure 8-2. With a properly damped probe input, the loading/input impedance will never drop below the value of the damping resistor.

250MHz Clock, 100ps Rise Time

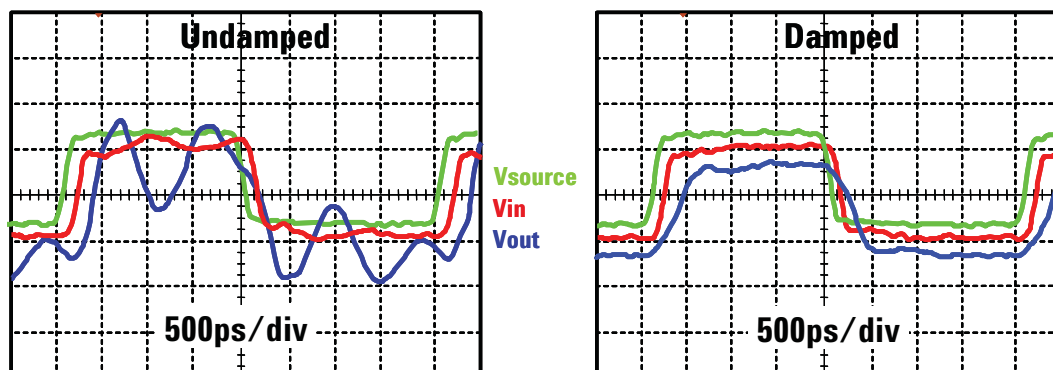
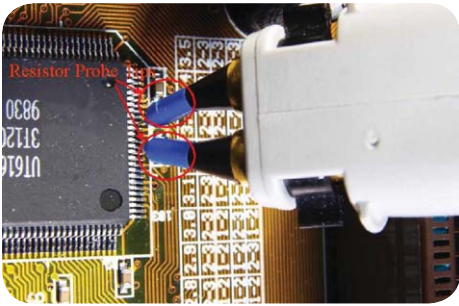

Figure 8-3. As the speeds in your design increase, you may notice more overshoot, ringing and other perturbations. Overcome the resonance formed by the connection of a probe by adding a damp resistor to your probe tip.



This probe's damped accessories give a flexible use model that maintains low input capacitance and inductance and flat frequency response through its specified bandwidth. The entire 1156A/1157A/1158A Series and InfiniiMax Series probes use this damped accessory technology for optimum, but flexible performance.

Figure 8-4. The entire 1156A/1157A/1158A Series and InfiniiMax Series probes use this damped accessory technology for optimum, but flexible performance.

Reliable measurements start with the probe! Related Agilent literature

Publication Title	Publication Type	Publication Number
<i>Agilent Oscilloscope Probes and Accessories</i>	Selection guide	5989-6162EN
<i>InfiniiVision Oscilloscope Probes and Accessories</i>	Data sheet	5968-8153EN

To get the most out of your oscilloscope, you need the right probes and accessories for your particular applications. Please call the measurement specialists at Agilent or visit www.agilent.com/find/scope_probes for information on our comprehensive array of scope probes and accessories.

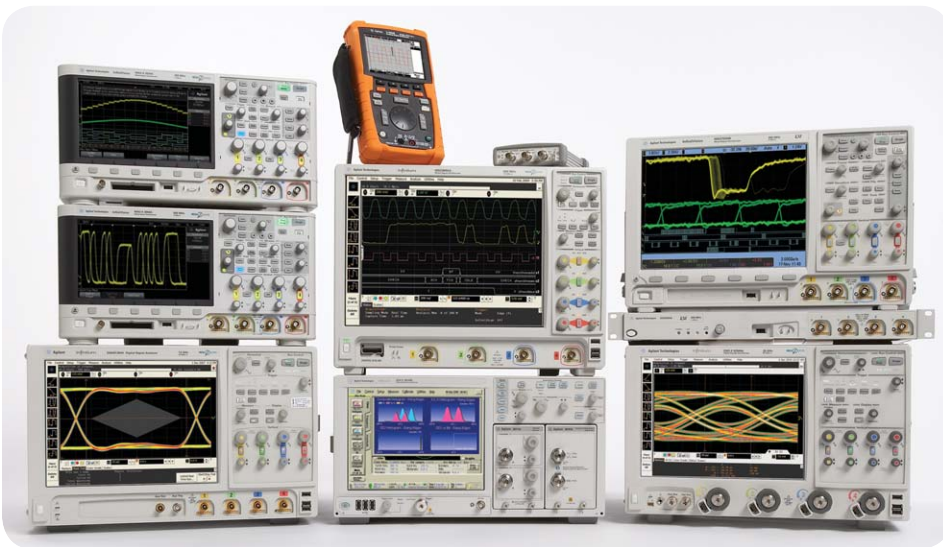

Agilent Technologies Oscilloscopes

Multiple form factors from 20 MHz to >90 GHz | Industry leading specs | Powerful applications

Agilent Email Updates

www.agilent.com/find/emailupdates

Get the latest information on the products and applications you select.



www.axistandard.org AdvancedTCA® Extensions for Instrumentation and Test (AXIe) is an open standard that extends the AdvancedTCA® for general purpose and semiconductor test. Agilent is a founding member of the AXIe consortium.



www.lxistandard.org

LXI is the LAN-based successor to GPIB, providing faster, more efficient connectivity. Agilent is a founding member of the LXI consortium.

Agilent Channel Partners

www.agilent.com/find/channelpartners

Get the best of both worlds: Agilent's measurement expertise and product breadth, combined with channel partner convenience.



Agilent Advantage Services is committed to your success throughout your equipment's lifetime. We share measurement and service expertise to help you create the products that change our world. To keep you competitive, we continually invest in tools and processes that speed up calibration and repair, reduce your cost of ownership, and move us ahead of your development curve.

www.agilent.com/find/advantageservices



www.agilent.com/quality

www.agilent.com

For more information on Agilent Technologies' products, applications or services, please contact your local Agilent office. The complete list is available at:

www.agilent.com/find/contactus

Americas

Canada	(877) 894 4414
Brazil	(11) 4197 3500
Mexico	01800 5064 800
United States	(800) 829 4444

Asia Pacific

Australia	1 800 629 485
China	800 810 0189
Hong Kong	800 938 693
India	1 800 112 929
Japan	0120 (421) 345
Korea	080 769 0800
Malaysia	1 800 888 848
Singapore	1 800 375 8100
Taiwan	0800 047 866
Other AP Countries	(65) 375 8100

Europe & Middle East

Belgium	32 (0) 2 404 93 40
Denmark	45 70 13 15 15
Finland	358 (0) 10 855 2100
France	0825 010 700*
	*0.125 €/minute
Germany	49 (0) 7031 464 6333
Ireland	1890 924 204
Israel	972-3-9288-504/544
Italy	39 02 92 60 8484
Netherlands	31 (0) 20 547 2111
Spain	34 (91) 631 3300
Sweden	0200-88 22 55
United Kingdom	44 (0) 118 9276201

For other unlisted Countries:

www.agilent.com/find/contactus

Revised: October 14, 2010

Product specifications and descriptions in this document subject to change without notice.

© Agilent Technologies, Inc. 2011
Printed in USA, May 24, 2011
5989-7894EN



Agilent Technologies